

S600

Specifications

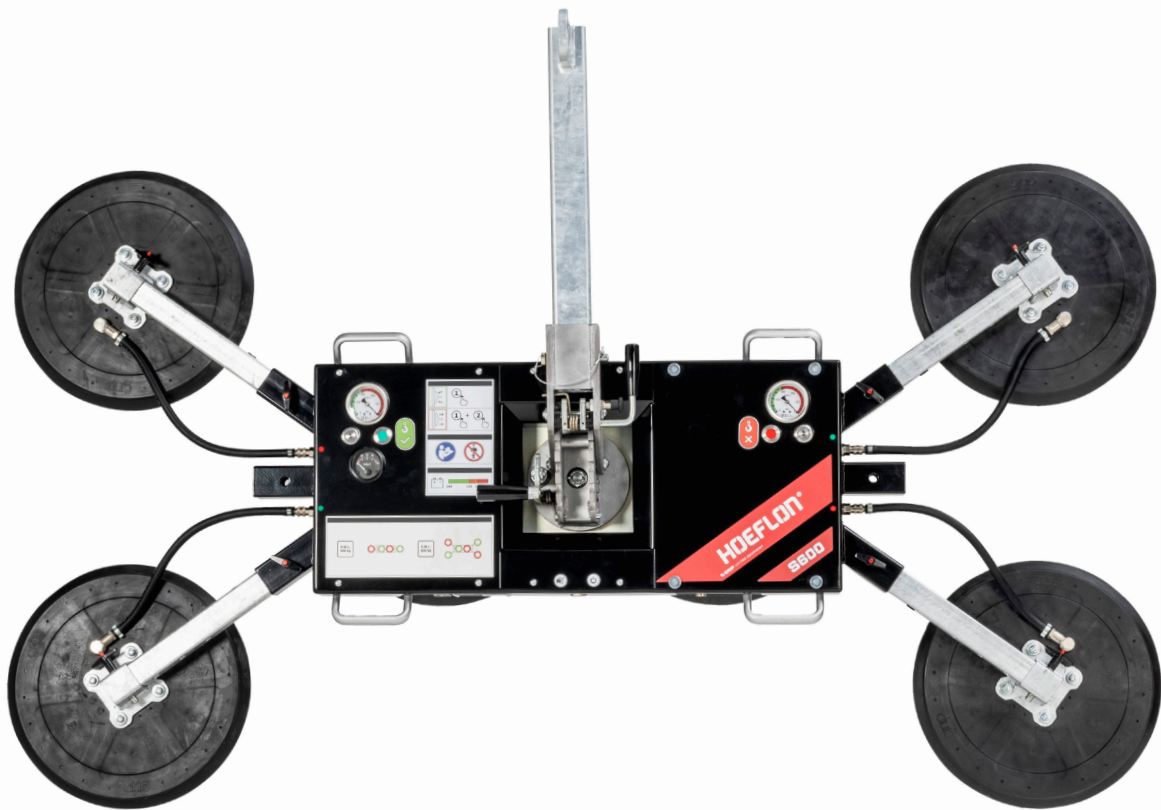

Lifting capacity Dual Circuit:	300 / 450 / 600 kg
Machine weight:	54 / 63 / 70 kg
Rotation range:	360° with four locking positions
Tilting range:	90° with six locking positions
Machine height:	190 mm
Battery:	12VDC, 9Ah

S600

Specifications

The vacuum lifter for glass up to 600 kg. Equipped with double vacuum system as standard. The various configurations make this machine our all-rounder, suitable for projects small and large.

Unique features

- Compatible with spider and inline suction lifters
- Compact transport on trolley
- Machine weight: 85 - 100 kg
- Maximum lifting capacity: 600 kg

Delivered standard with:

- Remote control
- Transport trolley
- Long lifting arm
- Short lifting arm
- Swappable battery system incl. spare battery
- Protective covers for suction cups

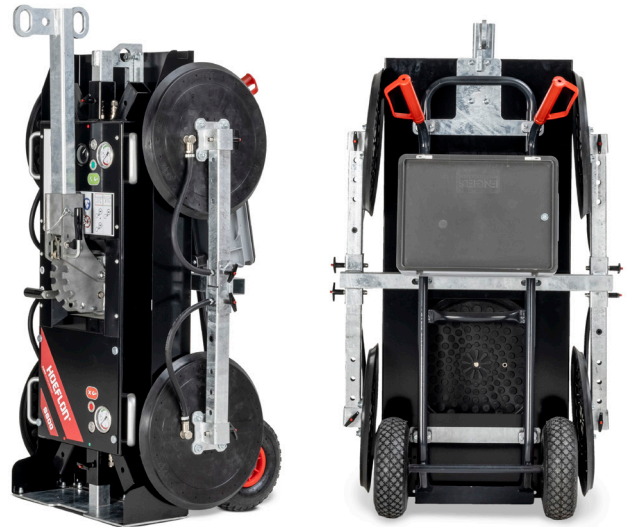

Specifications

- Manual tilting with 6 locking positions and continuous adjustment
- Manual rotation with 4 locking positions
- Radio remote control of suction and release
- Interchangeable lifting point for lower overall height
- Transport trolley with pneumatic tyres

Accessories



Battery



Battery charger



Remote control



Lifting arm

300 kg - Compact

Single circuit

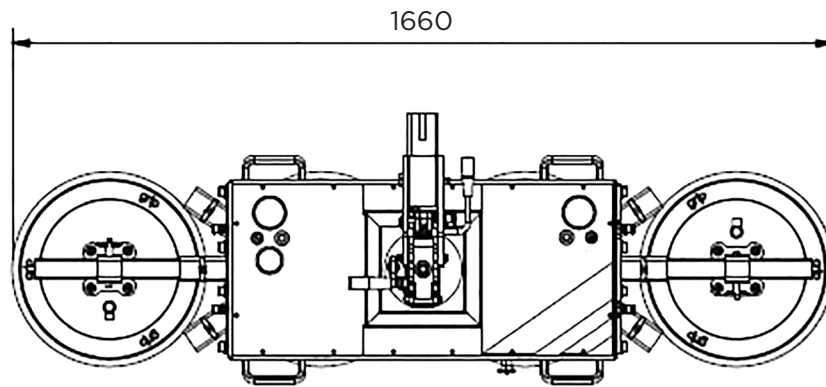

300 kg - Inline suction lifter

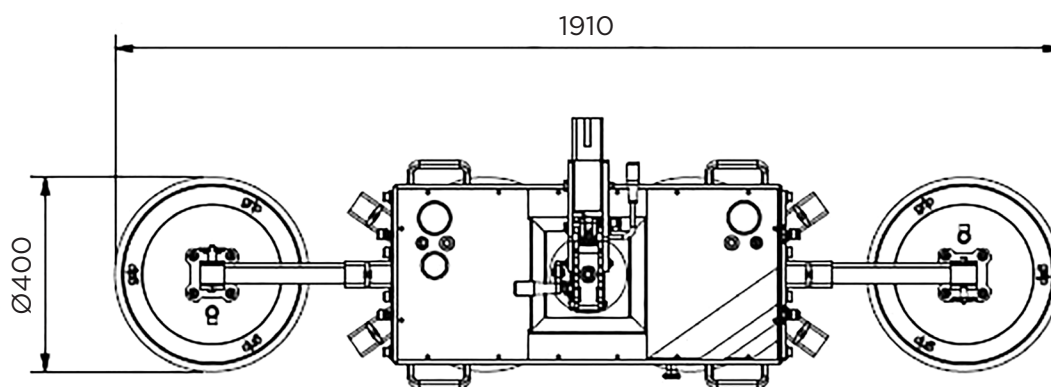

S600

Specifications

450 kg - Inline suction lifter, long

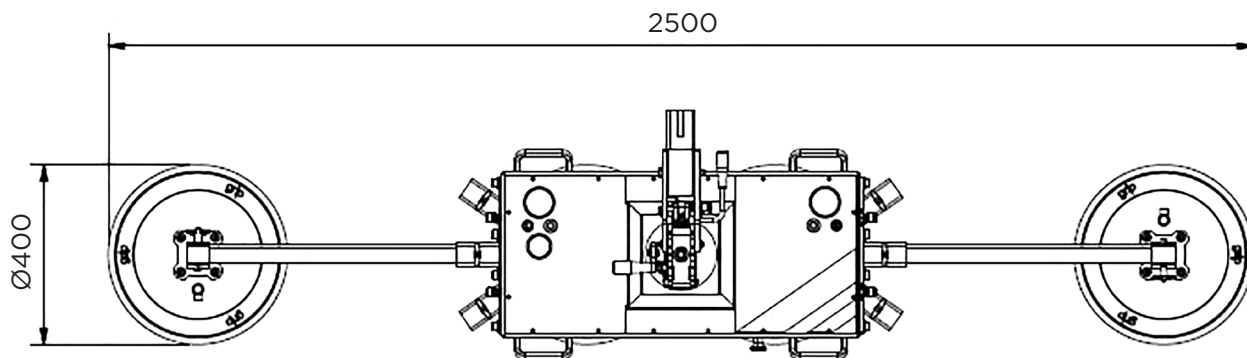

600 kg - Spider suction lifter

Short lifting arm

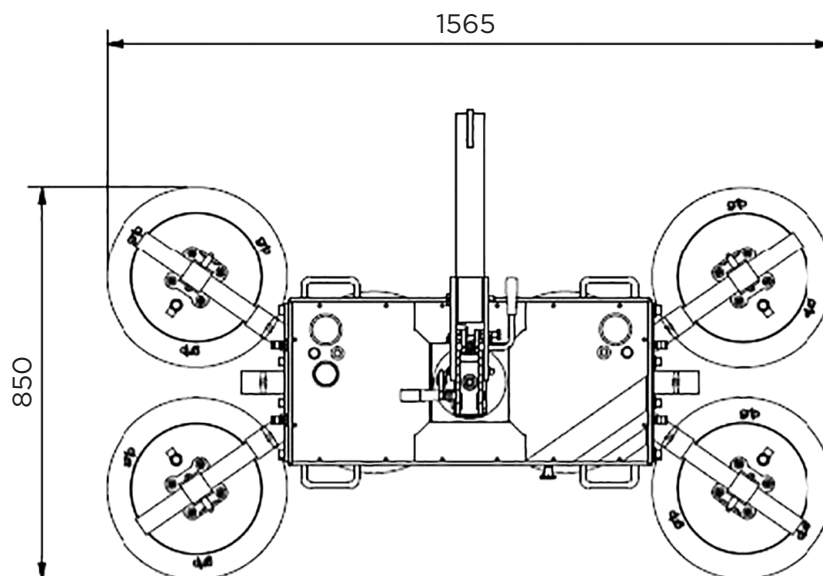

600 kg - Spider suction lifter

Long lifting arm

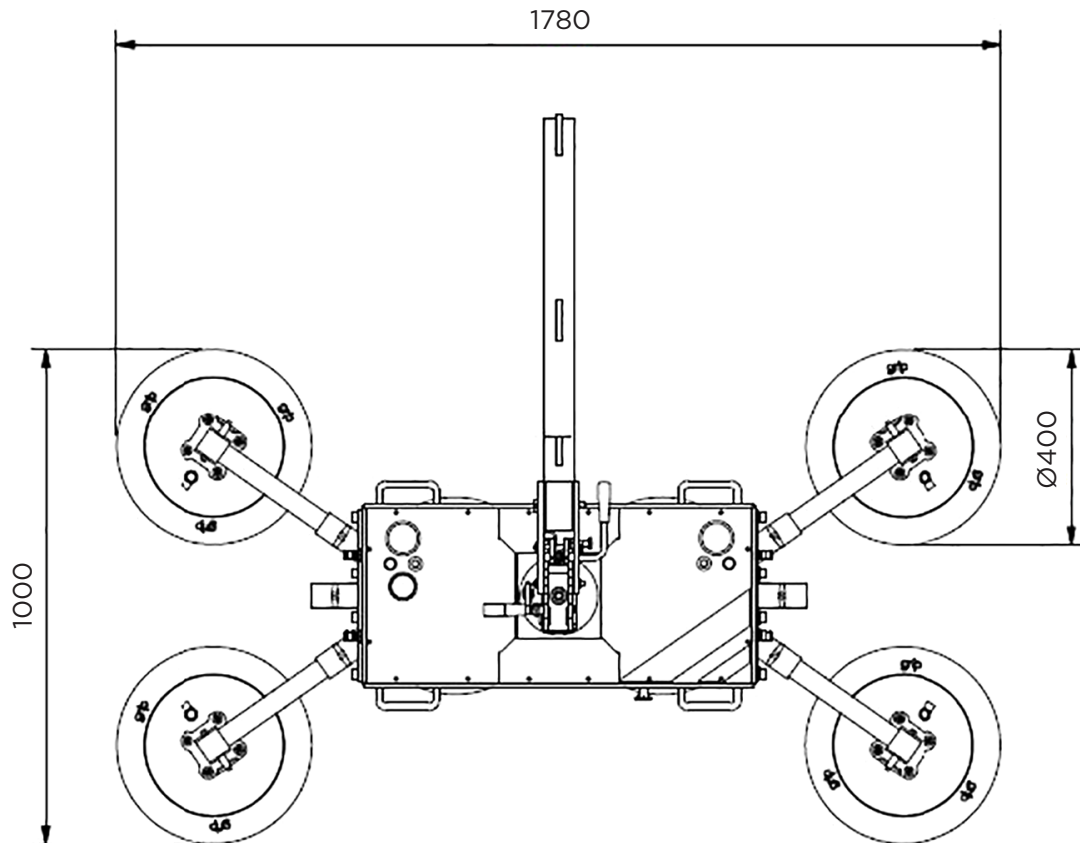

S600

Specifications

HOEFLON®

Your Hoeflon contact person

Hoeflon machines are functional and offer optimal power and reliability. We offer many possibilities and help you come up with solutions.

