

S1000

Specifications

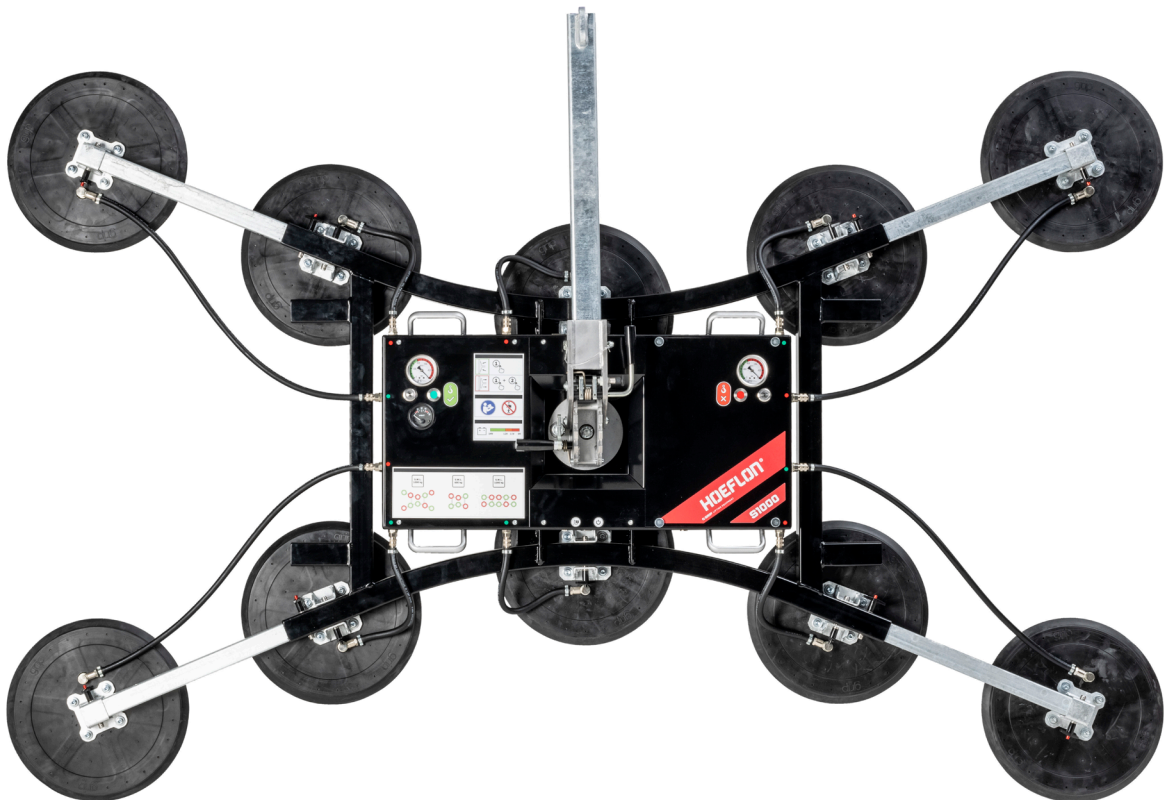

Lifting capacity Dual Circuit:	600 / 1000 kg
Machine weight:	85 / 110 kg
Rotation range:	360° with four locking positions
Tilting range:	90° with six locking positions
Machine height:	190 mm
Battery:	12VDC, 10Ah

S1000

Specifications

The Hoeflon S1000 suction lifter is a premium quality multifunctional glass lifter, with exceptional fit and finish, at a very competitive price.

All our products are designed in close cooperation with users from the field. This results in products that are a class apart when it comes to the details and provide the user with every convenience in daily use.

Unique features

- Compact basic unit for glass with small dimensions
- Spider shape with large spread provides greater ease of installation, speed and safety with large-sized glass
- Lightweight design

Delivered standard with:

- Remote control
- Transport trolley
- Long lifting arm
- Short lifting arm
- Swappable battery system incl. spare battery
- Protective covers for suction cups

Accessories

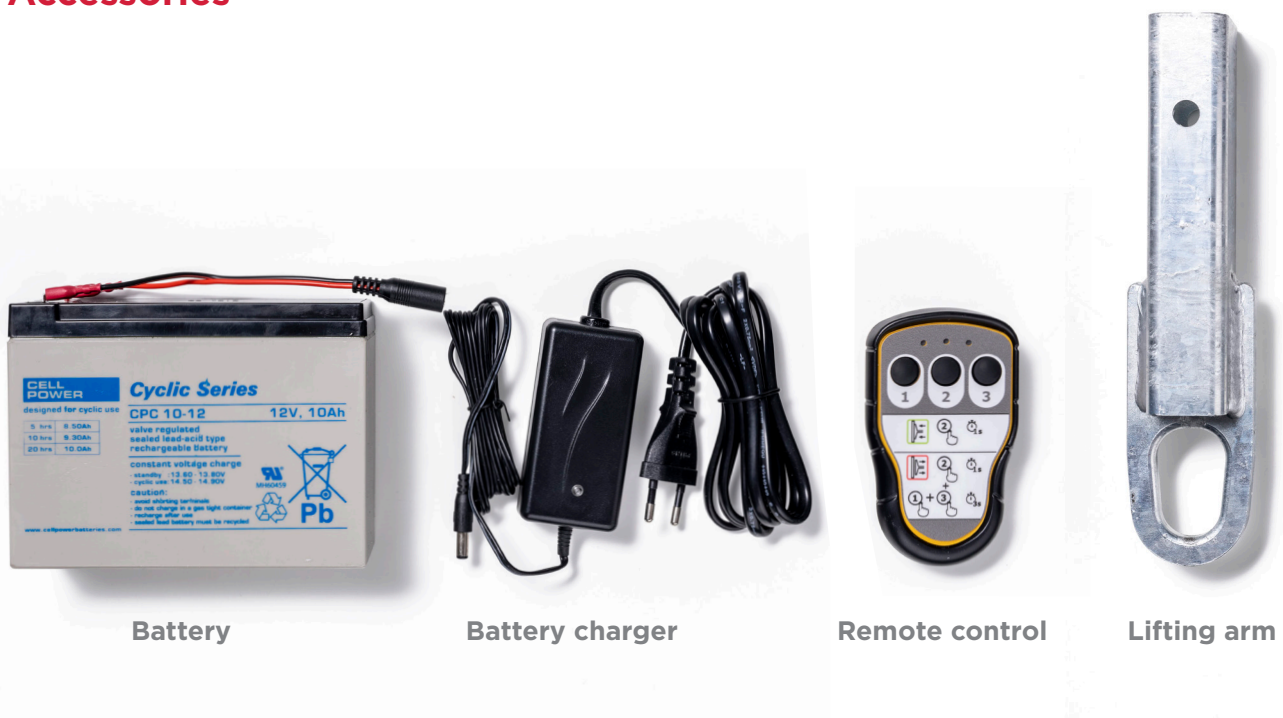

Battery

Battery charger

Remote control

Lifting arm

Specifications

- ▶ Short lifting arm provides very compact dimensions for when glass installation space is limited
- ▶ Long lifting arm allows almost vertical hanging of large-sized glass
- ▶ Angle adjustment on the Hoeflon lifting arm provides extra safety and convenience for indoor glazing installation because the angle can be fixed in different positions
- ▶ Double vacuum circuit, meeting the requirements of the EN 13155 directive, ensures maximum safety and installation speed because external fall protection is no longer necessary
- ▶ Radio remote control provides extra installation speed and convenience
- ▶ The overall width of the machine is very low, which means that work can also be carried out between the façade and scaffolding

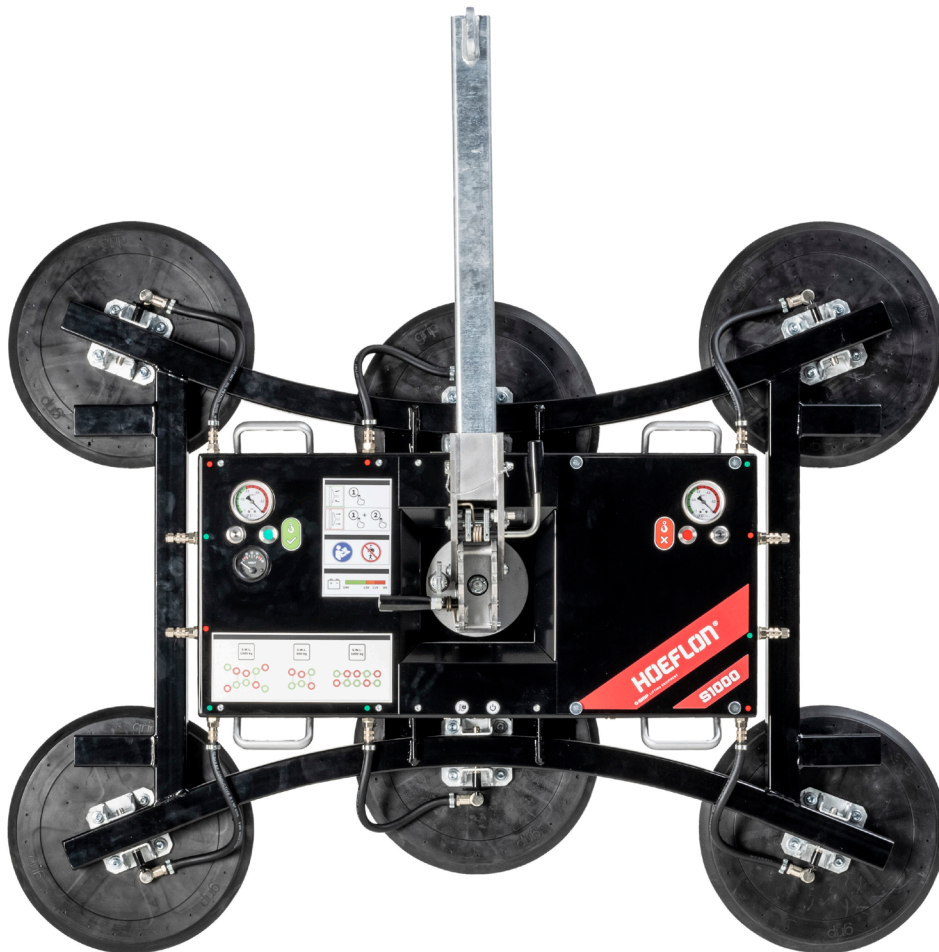

S1000

Specifications

SWL 600 kg - Spider suction lifter (85 kg)

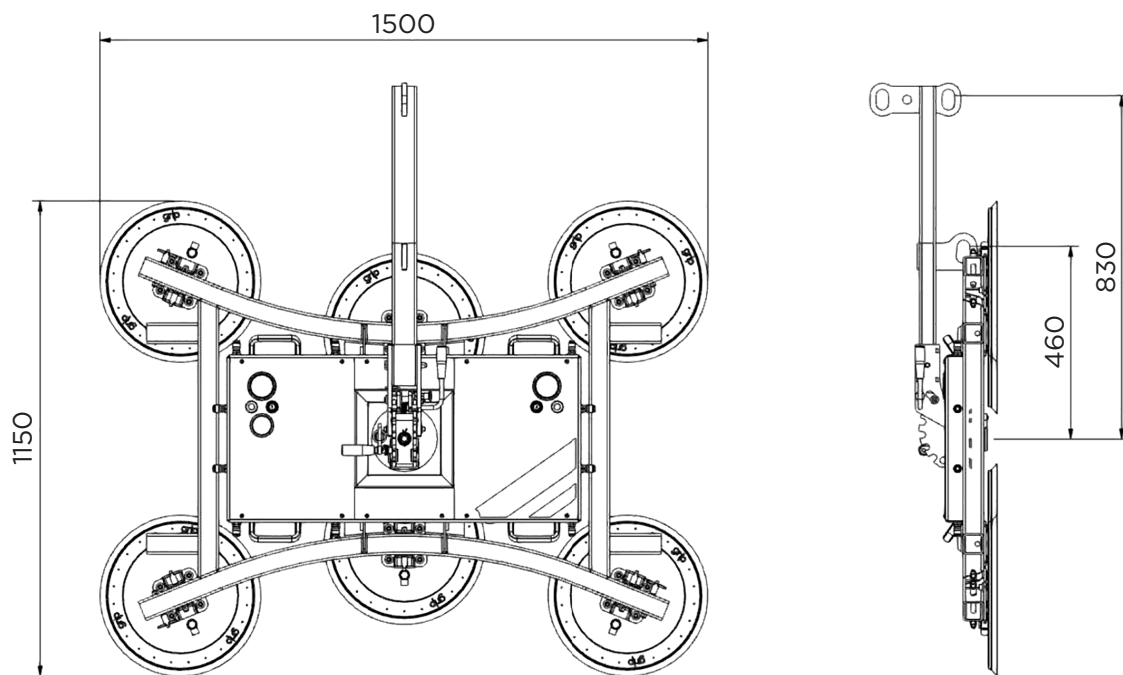

SWL 1000 kg - Inline suction lifter (110 kg)

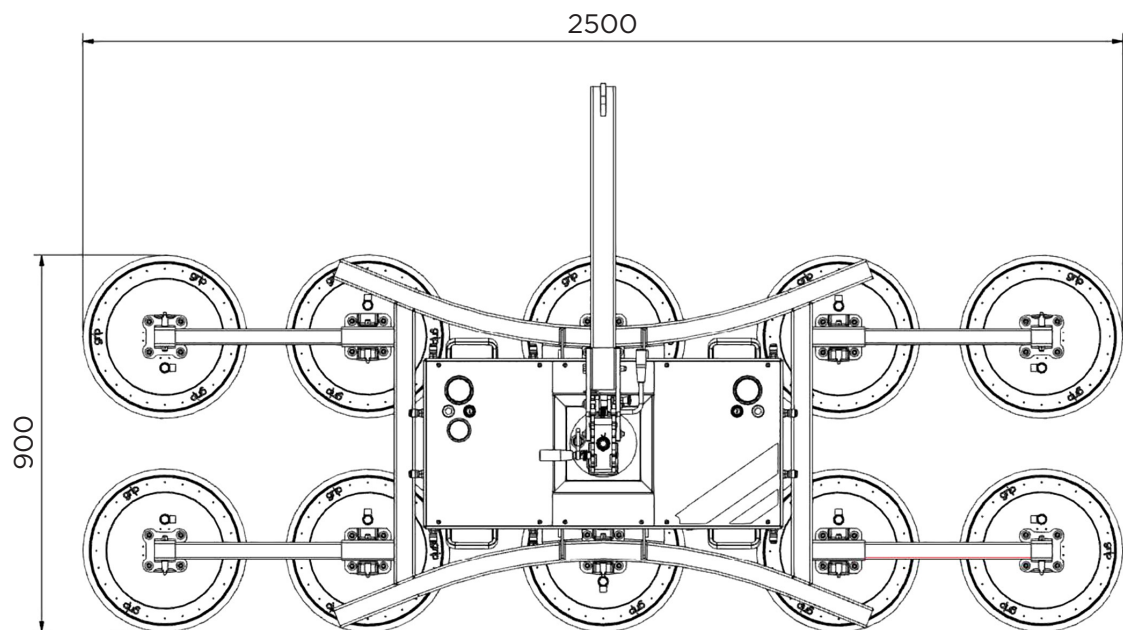

SWL 1000 kg - Spider suction lifter (110 kg)

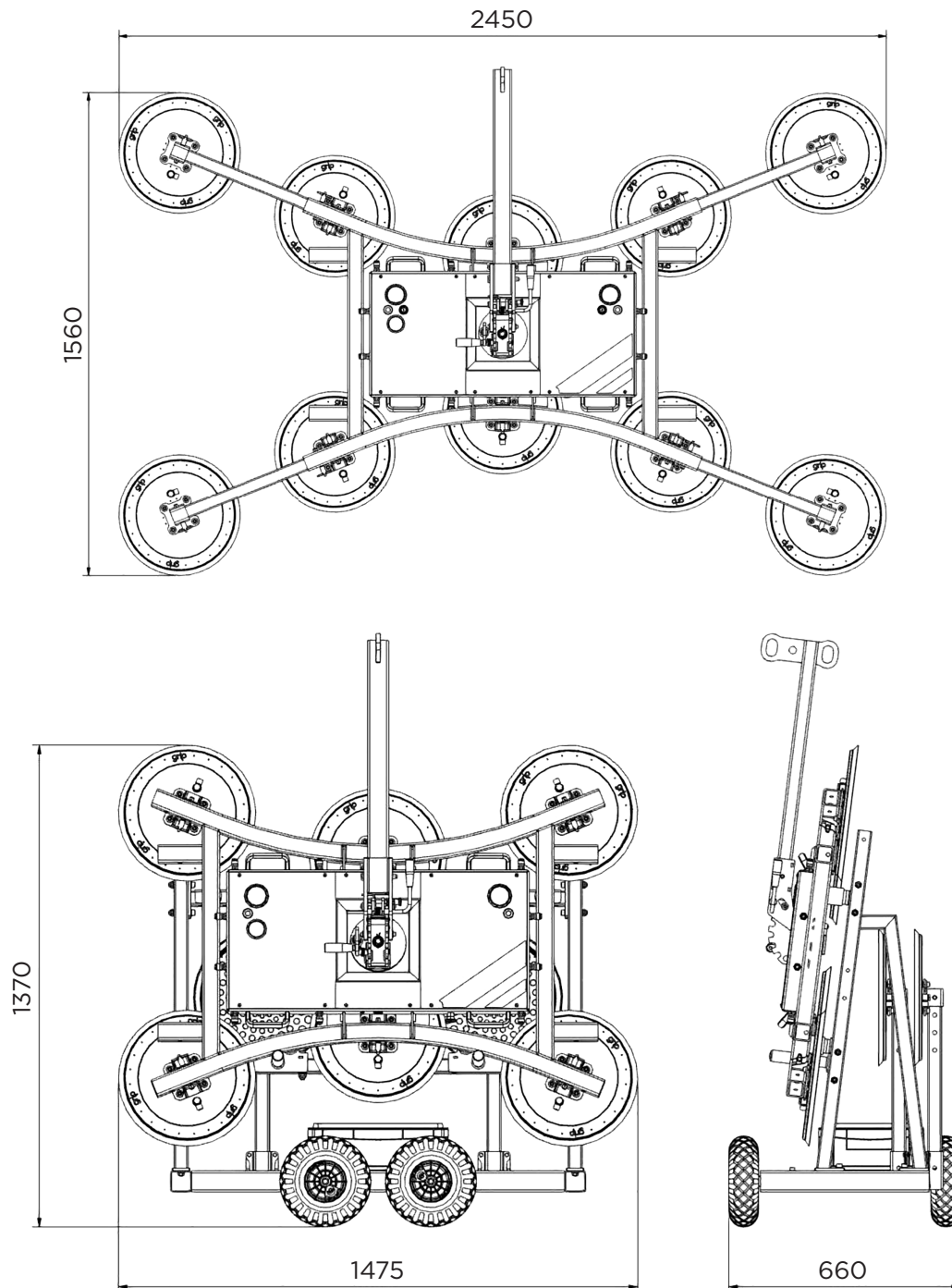

S1000

Specifications

HOEFLON®

Your Hoeflon contact person

Hoeflon machines are functional and offer optimal power and reliability. We offer many possibilities and help you come up with solutions.



www.gantic.no
55 31 55 31
post@gantic.no

Bleivassvegen 34
5347 Ågotnes
Norway