

KL26

KLUBB®

CONFIDENCE AT ITS HIGHEST LEVEL

AERIAL PLATFORM MOUNTED ON PIAGGIO PORTER NP6



Working Height



GANTIC
+47 55 31 55 31
<https://www.gantic.no>
Bleivassvegen 34,
5347 ÅGOTNES, Norway



KL26 TELESCOPIC AERIAL PLATFORM

mounted on chassis



WORKING DIAGRAM

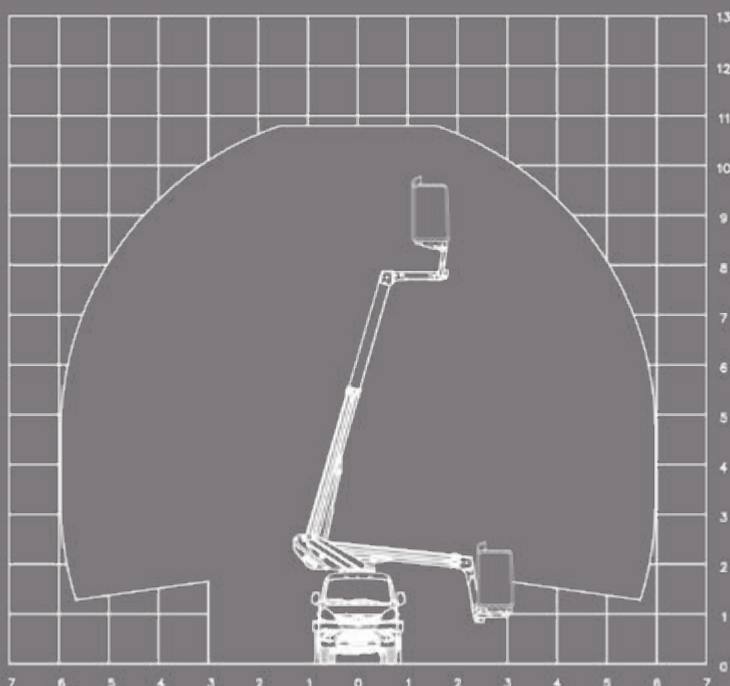

VEHICLE DRAWING

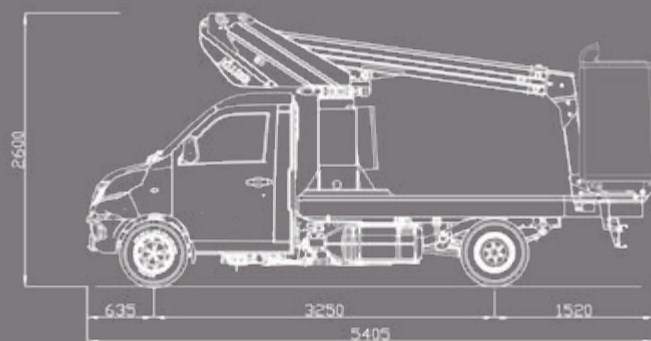

STANDARD SPECIFICATIONS

- Independent emergency manual pump with all the features in the basket for maximum security
- Proportional controls
- Secure access to the working platform
- Hoses and cables are inside the boom structure for maximum protection
- Aluminium boom for optimum stability

AERIAL PLATFORM OPTIONS

- Signalling devices
- 220V electric socket in basket
- Water / air circuit in basket
- Fully opening insulated basket
- Removable tool holder in basket
- Side chests
- Side panels

For more platform options, please contact us before ordering



10,70 m



6 m



8,70 m



360°



200 kg



2 A shaped outriggers



125 x 75 x 110 cm



Hour counter



≤ 3,5 T



POSSIBLE TYPES OF VEHICLES

PIAGGIO PORTER NP6 Bi-Carburation essence/GPL or essence/GNV

For vehicle options, please contact us before ordering

DEMONSTRATION ON DEMAND