

# XTENSO 3

# KLUBB®

CONFIDENCE AT ITS HIGHEST LEVEL

## AERIAL PLATFORM MOUNTED ON CHASSIS



Working height



GANTIC  
+47 55 31 55 31  
<https://www.gantic.no>  
Bleivassvegen 34,  
5347 ÅGOTNES, Norway



# TELESCOPIC AERIAL PLATFORM

## mounted on chassis

# XTENSO 3<sup>®</sup>

### WORKING DIAGRAM

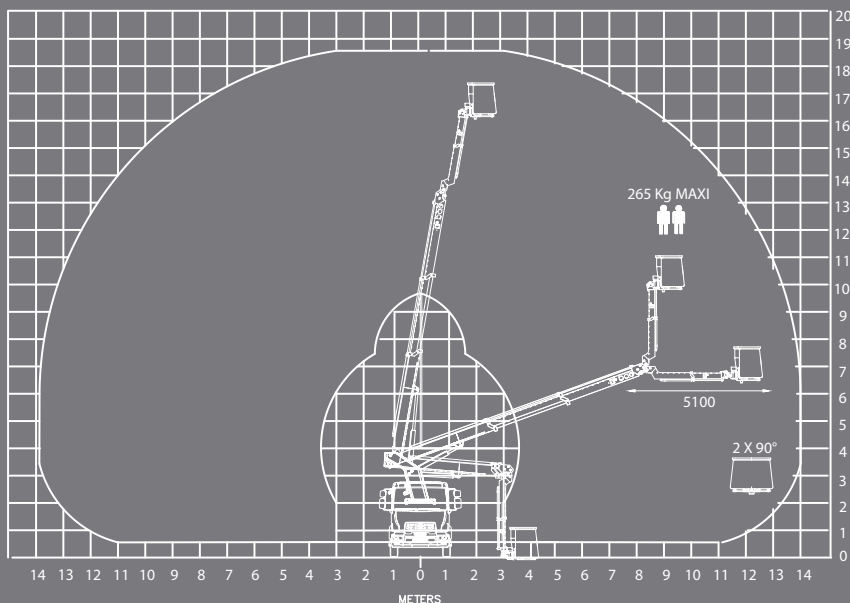

### VEHICLE DRAWING

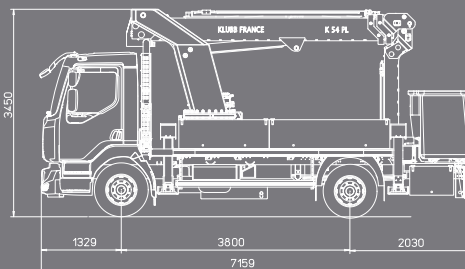

### PORTEURS POSSIBLES

- MAN TGL
- MAN TGM
- IVECO EUROARGO
- RENAULT D
- MERCEDES ATEGO
- MERCEDES UNIMOG
- PTAC : from 14 ton

For vehicle options, please contact us before ordering  
Installation on lower tonnages, please contact us



18.50m  
(60'8")



13.90m  
(45'7")

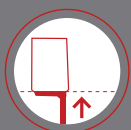

16.50m  
(54'2")



420°



Jib



265kg



Four  
outriggers



89 x 115 x 156cm



Hour  
counter

### STANDARD SPECIFICATIONS

- Engine start and stop from basket
- Stabilization with independent controls in the basket and from the ground
- Independent emergency manual pump
- Proportional controls on all movements
- Secure access to the working platform
- Hoses and cables are inside the boom structure for maximum protection
- Automatic centering of the platform and the turret
- Lifting arm consisting of a double telescope and a telescopic jib with 180° orientation
- Telescopic jib for an overhang of more than 5.10m and allowing 360° access to the ground
- Hydraulic rotation of the basket in all positions



### AERIAL PLATFORM OPTIONS

- Signaling devises (triflash, 2 flashing lights, reflective strips)
- 220V electric socket in the basket
- Trailer hook
- Reinforced suspensions
- Fully opening insulating baasket
- Aluminium chests
- Ladder rack
- Cycle of use without outriggers
- Green Pack: the platform can be operated with the van engine turned off

For more platform options, please contact us before ordering

**/ DEMONSTRATION ON DEMAND**

