

XTENSO 3

KLUBB®

CONFIDENCE AT ITS HIGHEST LEVEL

AERIAL PLATFORM WORKSHOP VERSION



Working height



GANTIC
+47 55 31 55 31
<https://www.gantic.no>
Bleivassvegen 34,
5347 ÅGOTNES, Norway



TELESCOPIC AERIAL PLATFORM

mounted on chassis - Workshop version

XTENSO 3[®]

WORKING DIAGRAM

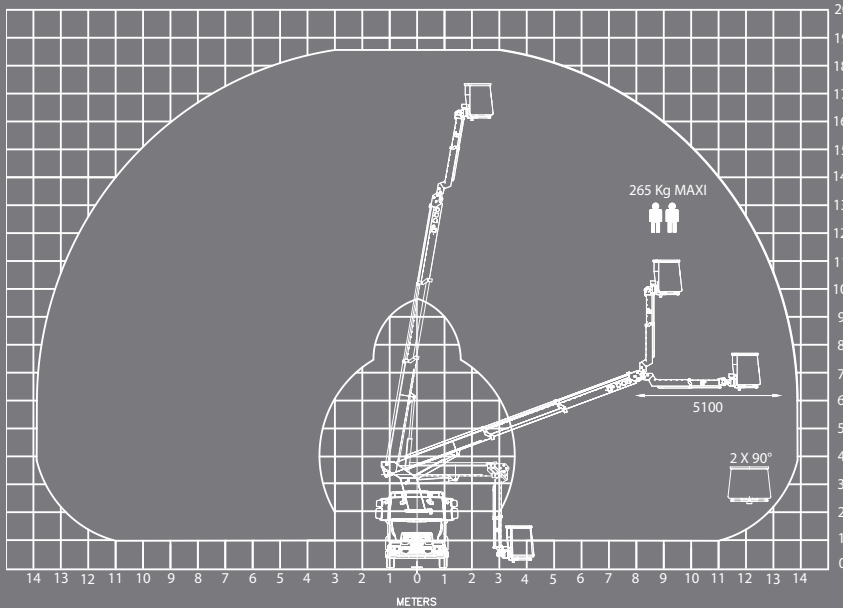

VEHICLE DRAWING

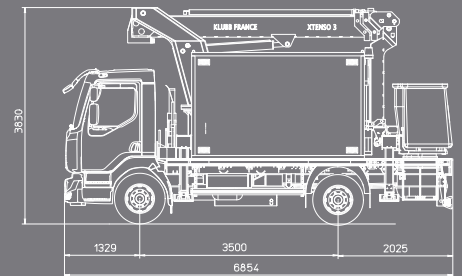

PORTEURS POSSIBLES

- MAN TGL
- MAN TGM
- IVECO EUROCARGO
- RENAULT D
- MERCEDES ATEGO
- MERCEDES UNIMOG
- PTAC : from 14 ton

For vehicle options, please contact us before ordering
Installation on lower tonnages, please contact us



18.50m
(60'8")



13.90m
(45'7")



16.50m
(54'2")



420°



Jib



265Kg



Four
outriggers



89 x 115 x 156cm



Hour
counter

STANDARD SPECIFICATIONS

- Engine start and stop from basket
- Stabilization with independent controls in the basket and from the ground
- Independant emergency manual pump
- Proportional controls on all movements
- Secure access to the working platform
- Hoses and cables are inside the boom structure for maximum protection
- Automatic centering of the platform and the turret
- Lifting arm consisting of a double telescope and a telescopic jib with 180° orientation
- Telescopic jib for an overhang of more than 5.10m and allowing 360° access to the ground
- Hydraulic rotation of the basket in all positions



AERIAL PLATFORM OPTIONS

- Signaling devises (triflash, 2 flashing lights, reflective strips)
- 220V electric socket in the basket
- Trailer hook
- Reinforced suspensions
- Fully opening insulating baasket
- Aluminium chests
- Ladder rack
- Cycle of use without outriggers
- Green Pack: the platform can be operated with the van engine turned off

For more platform options, please contact us before ordering

/ DEMONSTRATION ON DEMAND



KLUBB | XTENSO3