

# ML-LINE

## MULTI-LOADER 6.0



CRAWLER CARRIER

ALMACRAWLER 

# MULTI LOADER 6.0

Transport capacity 6000 kg

Power options: diesel engine, full-electric, bi-energy

Self-levelling up to 20°

Radio remote controller

Capacità di trasporto 6000 kg

Opzioni di alimentazione: motore diesel, completamente elettrico, bi-energy

Autolivellante fino a 20°

Radiocomando



Autonomy Autonomia	Load / Portata			Max Speed Velocità max
	0 Kg	3.000 Kg	6.000 Kg	
	~2.500 m	~2.000 m	~1.300 m	1,7 Km/h

## MULTI-LOADER 6.0 ELC

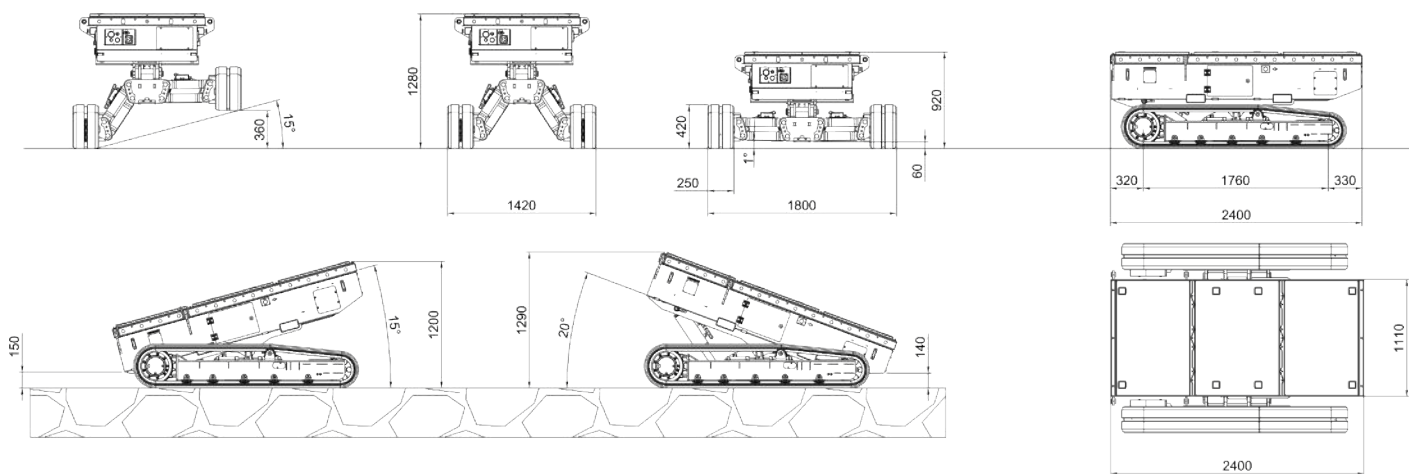

## MULTI-LOADER 6.0 EVO / BI-ENERGY

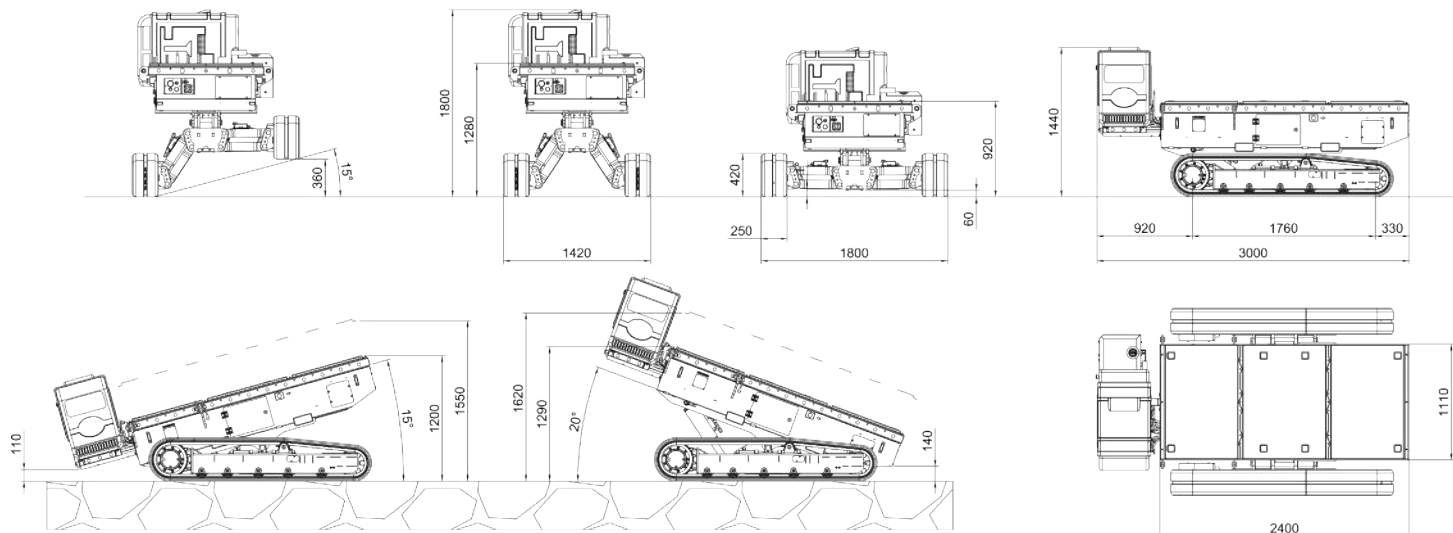

## Technical data

## ML 6.0

## Dati tecnici

Max Capacity	6000 kg (5500 kg with Crane)	Portata
Dynamic levelling	Yes/ Si	Dynamic levelling
Undercarriage	Bi-levelling	Sottocarro
Longitudinal levelling Front	20°	Livellamento longitudinale Anteriore
Longitudinal levelling Rear	15°	Livellamento longitudinale Posteriore
Lateral levelling	+/- 15°	Livellamento laterale
Hydraulic commands	Proportionals	Comandi idraulici
Direction-Control System	Yes/Si	Direction-Control System
Easy-Drive System	Yes/Si	Easy-Drive System
Control of inclination	Automatic	Controllo dell'inclinazione
Gradeability	25°	Pendenza superabile
Side slope	25°	Massima pendenza laterale
Consolle	Remote	Console

## Size

### ELC

### EVO

### BI-ENERGY

## Dimensioni

Min Width	1.42 m	1.42 m	1.42 m	Larghezza minima
Max Width	1.8 m	1.8 m	1.8 m	Larghezza massima
Min height	0.92 m	1.44 m	1.44 m (2.61 m with Crane)	Altezza minima
Length	2.4 m	3.0 m	3.0 m	Lunghezza
Total weight	2250 kg	2250 kg	2550 kg (2990 kg with Crane)	Peso totale

## Power

## Potenza

Engine	-	Yanmar 3TNV76 (diesel) - 25HP	Yanmar 3TNV76 (diesel) - 25HP	Motore
Electric engine	48V - 3kW	-	48V - 3kW	Motore elettrico
Battery pack & battery charger	Lead Crystal n°8 180Ah 48V n°2 20Ah-110/220V	-	Lead Crystal n°8 180Ah 48V n°2 20Ah-110/220V	Pacco batteria & caricabatteria
Electric pump	-	220V-2kW or 110V-1,9kW	-	Elettropompa
Max speed	max 1.7 km/h	max 1.7 km/h	max 1.7 km/h	Velocità max

## REMOVABLE ENGINE\*

The diesel engine can be easily removed to free the platform - the ML 6.0 uses the battery as main source!

\*only on ML 6.0 BI-ENERGY

## MOTORE RIMOVIBILE\*

Il motore diesel può essere facilmente rimosso per liberare il pianale da ingombri: il ML 6.0 utilizza il pacco batterie come fonte di alimentazione principale!

\*solo su ML 6.0 BI-ENERGY



Simplify and centralize the management of all after-sales activities, spare parts purchasing and warranty procedures.

Semplifica e centralizza la gestione di tutte le attività post vendita, acquisto ricambi e richieste di garanzia.

**MYALMAC  
CONTROL  
PANEL**

**ALMACRAWLER**

# 4.1 T-CRANE MULTI-LOADER 6.0

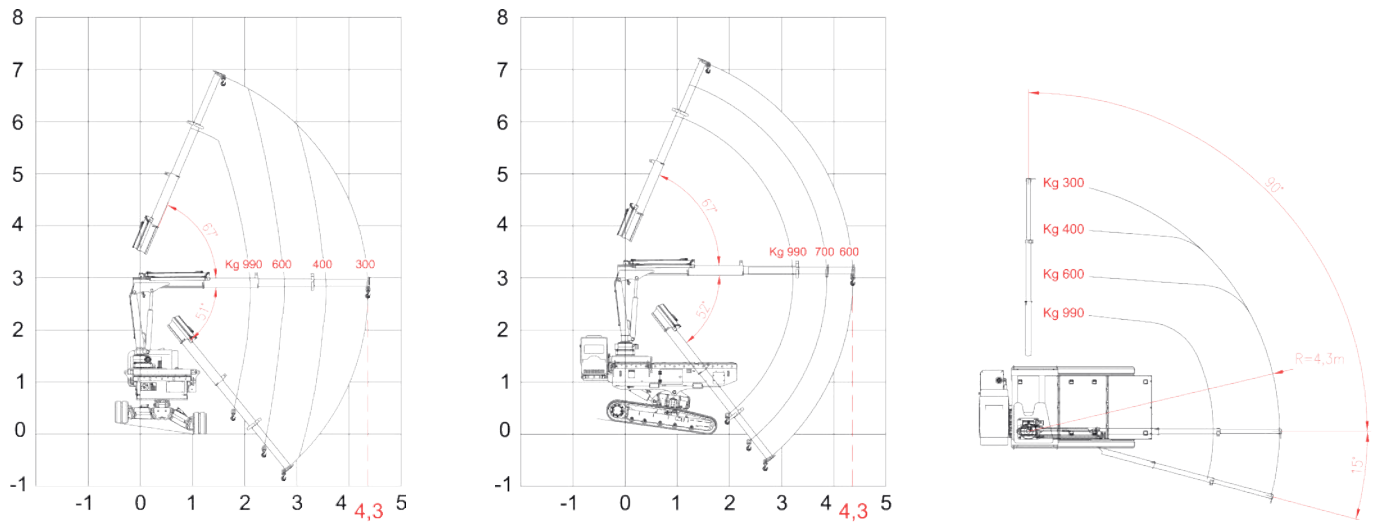
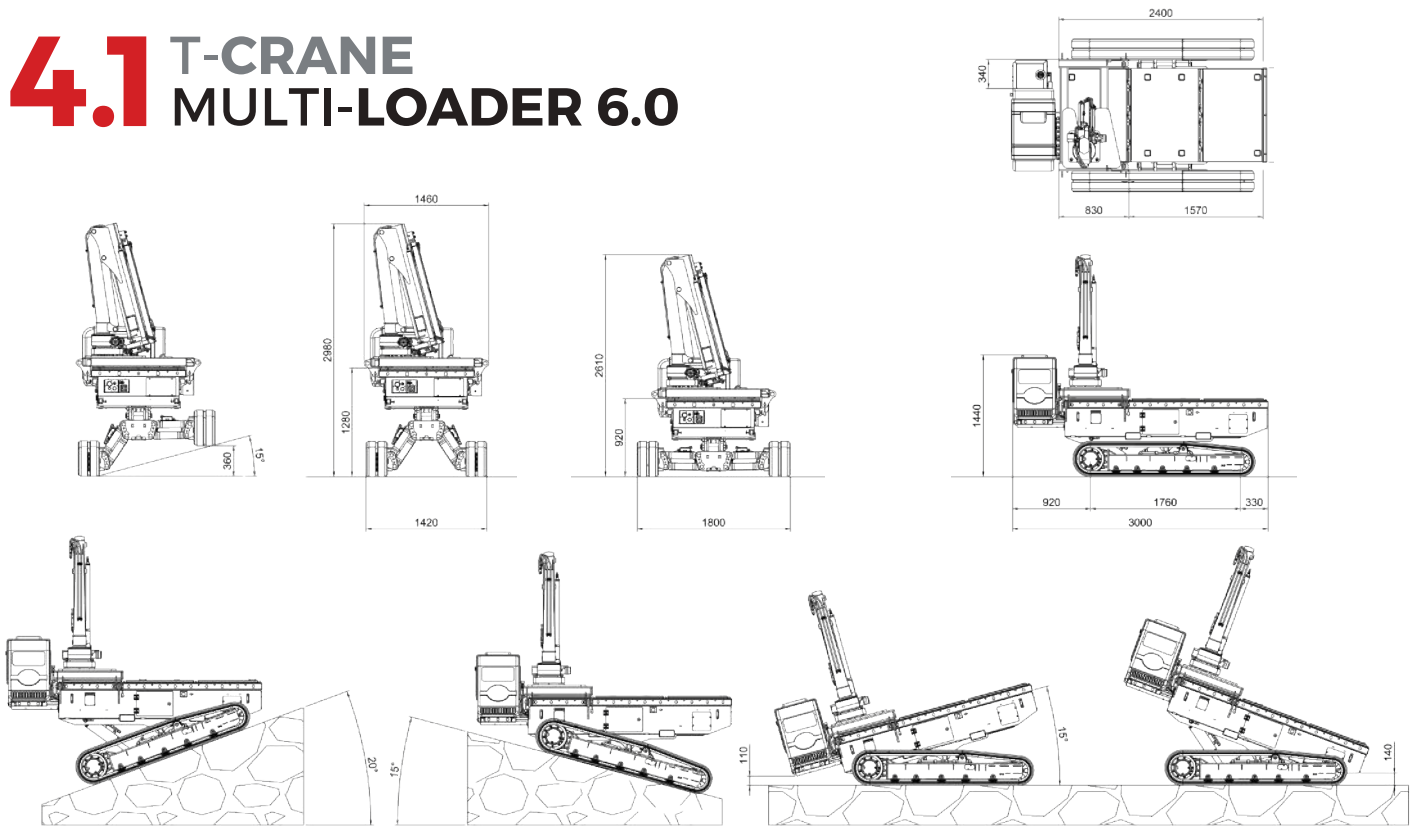

only on / solo su  
MULTI-LOADER 6.0 EVO BI-ENERGY

**T-CRANE kit** (removable)

**Self-propelled crane**  
Gru semovente

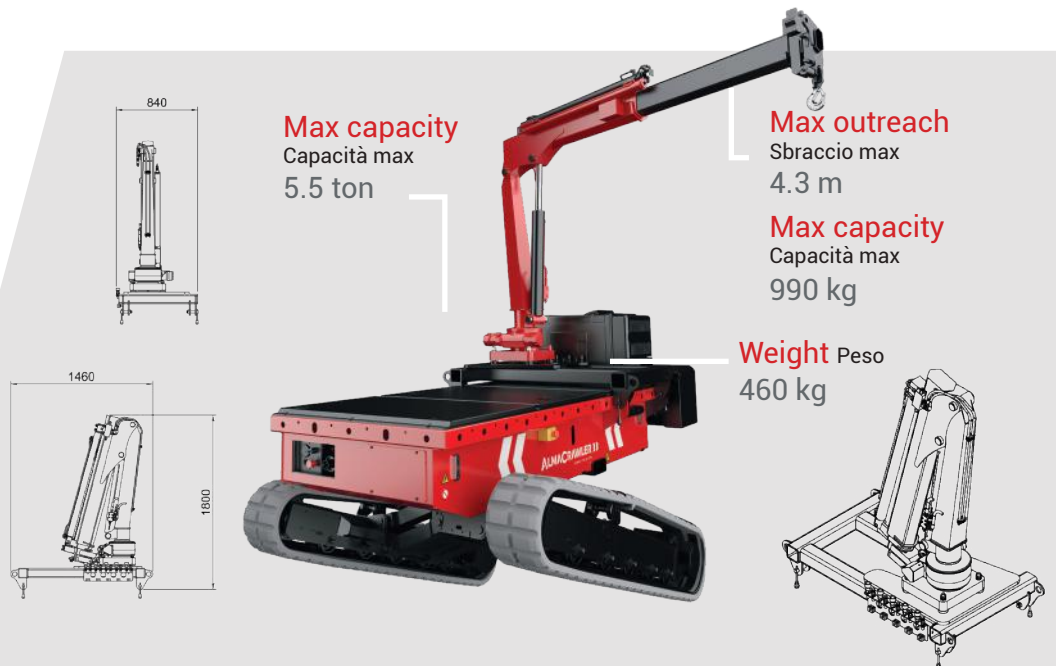

Via Caduti sul Lavoro 1  
46019 Viadana (MN) - ITALY  
+39 0375 83 35 27  
info@almac-italia.com

Rev.02